

TECHNICAL DATA:

Number of cylinders 2
 Cylinder diameter 75 mm
 Piston stroke 48 mm
 Total piston displacement 424 cm³
 Mass 15,5 kg
 Working pressure 800 kPa
 Max. pressure for short time duty 1000 kPa
 Max. allowable temp. of compressed air +220 °C
 Cooling by inflation of air, with the speed of the stream min. -4m/s
 Lubrication forced circulation, splash lubrication at min. pressure of 200kPa
 admissible min. pressure only as regards to idle runing of engine -70kPa

SYMBOLS DESCRIPTION:

0 - suction connection (thread M22x1,5 length 12mm)
 2 - discharge connection (thread M22x1,5 length 12mm)
 81 - lubricating oil inlet (thread M10x1 length 12mm)
 82 - lubricating oil outlet and crankcase breathing (hole ø15)
 Numeral signs according to International Standard ISO-6786
 T - rating plate
 * - max. angular deflection of the compressor

Time to fill a tank of 40dm³ capacity

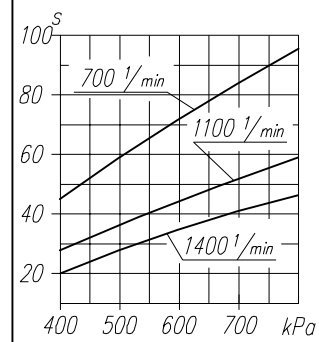

NOTE! The above characteristics are for open-inlet-valve control system at minimum cooling requirements and at ambient temperature +20°C

Variant of compressor	Localization of suction and discharge connections	T
602.05.913		P
602.05.914		L

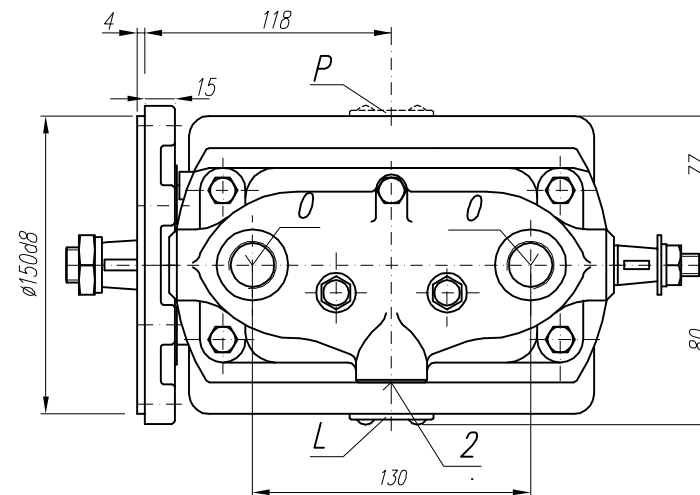
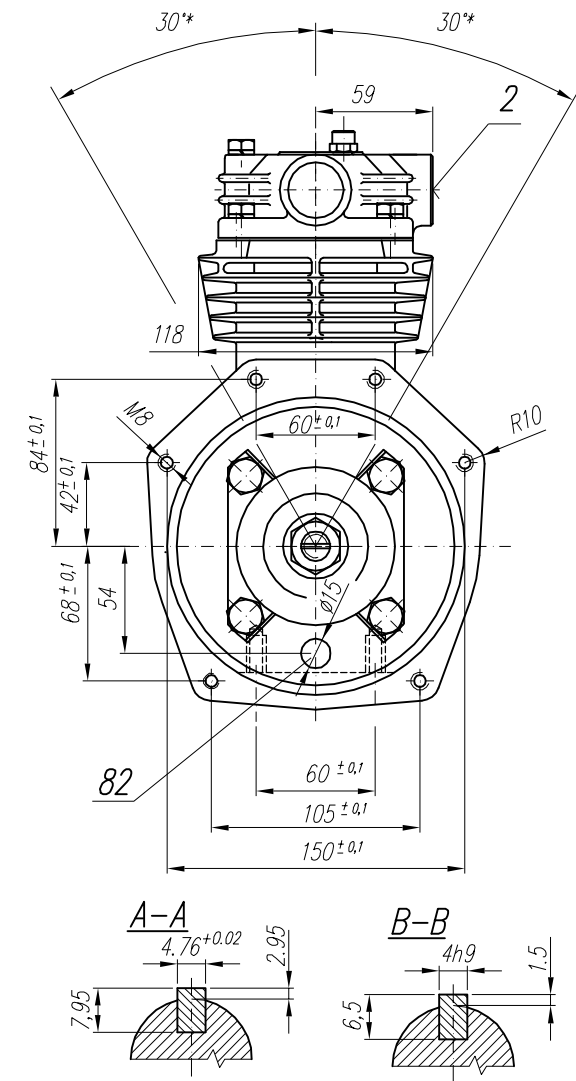
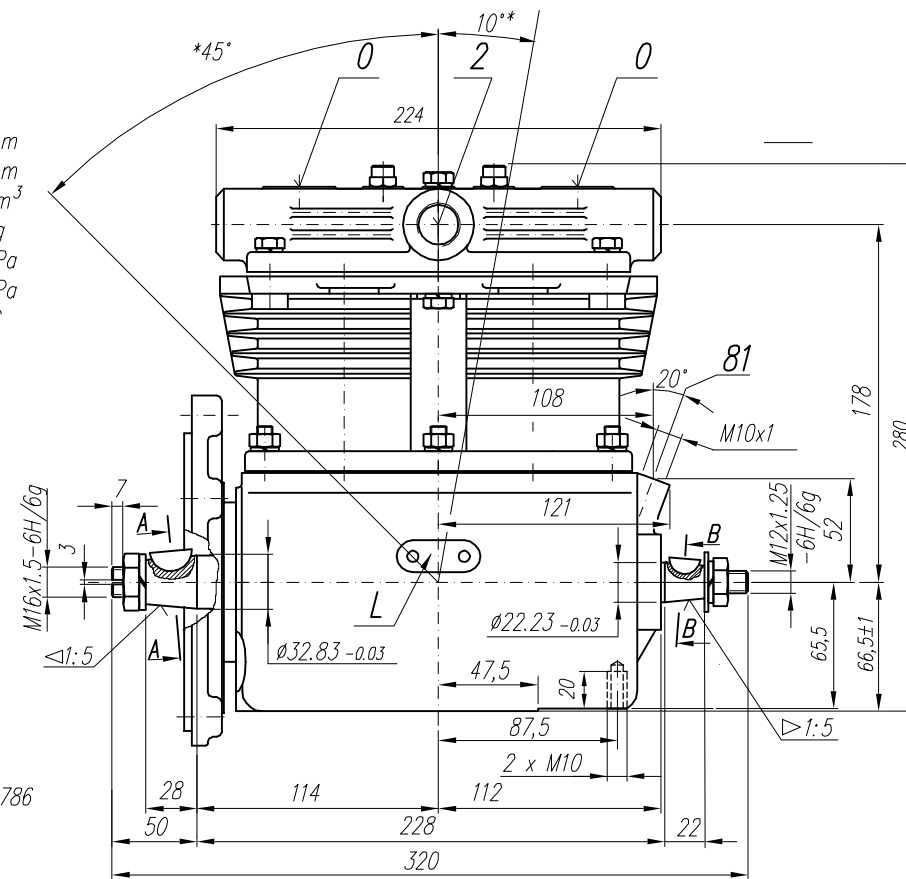

Zmiana x ilo??	data	ax	bx	cx	Fabryka Osprzetu Samochodowego POLMO-t?d? SA
nr. wprowadz.					DZIAŁ ROZWOJU
zm. wprowadz.					
Konstr. Malinowski	Mat. akcept.			Masa kg	Materia? ---
Kre?li? Malinowski	Normaliz. Boryna			Format 3xA4	
Sprawdz. Lesiak	Zatw. Kle?a			dn. 06.02.96	wg normy
Podzia?ka	Nazwa				Nr rys. 602.05.914
1:2,5	Compressor				