

NOTE! The above characteristics are for open-inlet-valve control system at minimum cooling requirements and at ambient temperature +20°C

DEFINITIONS: $CC=CT+CL$ - period of average operating cycle

$UC = \frac{CT}{CC} \times 100\%$ - percent ratio of compressor full load operating time in average operating cycle (also called percent duty cycle)
 CL - compressor no-load operating time (exhaust to the atmosphere)
 CT - compressor full load operating time

TECHNICAL DATA:

Number of cylinders 2
 Cylinder diameter 75 mm
 Piston stroke 48 mm
 Total piston displacement 424 cm³
 Mass 16.5 kg
 Working pressure 900 kPa
 Max. pressure for short time duty 1000 kPa
 Max. allowable temp. of compressed air +220 °C
 Cooling by circuit of the water min. flow temp. of water at the inlet max. 2dm³/min
 Lubrication forced circulation, splash lubrication min. pressure of oil 200kPa
 admissible min. pressure only as regards to idle tuning of engine 70kPa

SYMBOLS DESCRIPTION:

0 - suction connection (on the head signifying "S")
 2 - discharge connection (on the head signifying "D")
 3 - breather de-aeration of the water chamber
 81 - lubricating oil inlet
 82 - lubricating oil outlet and crankcase breathing
 9 - cooling water inlet or outlet (on the head signifying "W")
 Numeral signs according to International Standard ISO-6786
 T - rating plate
 * - max. angular deflection of the compressor
 BSF; BSPF - signs for thread according to British Standard:
 5/16" 22BSF acc. BS-84/1956 -middle class
 1/4" BSPF acc. BS-2779/1956 -middle class

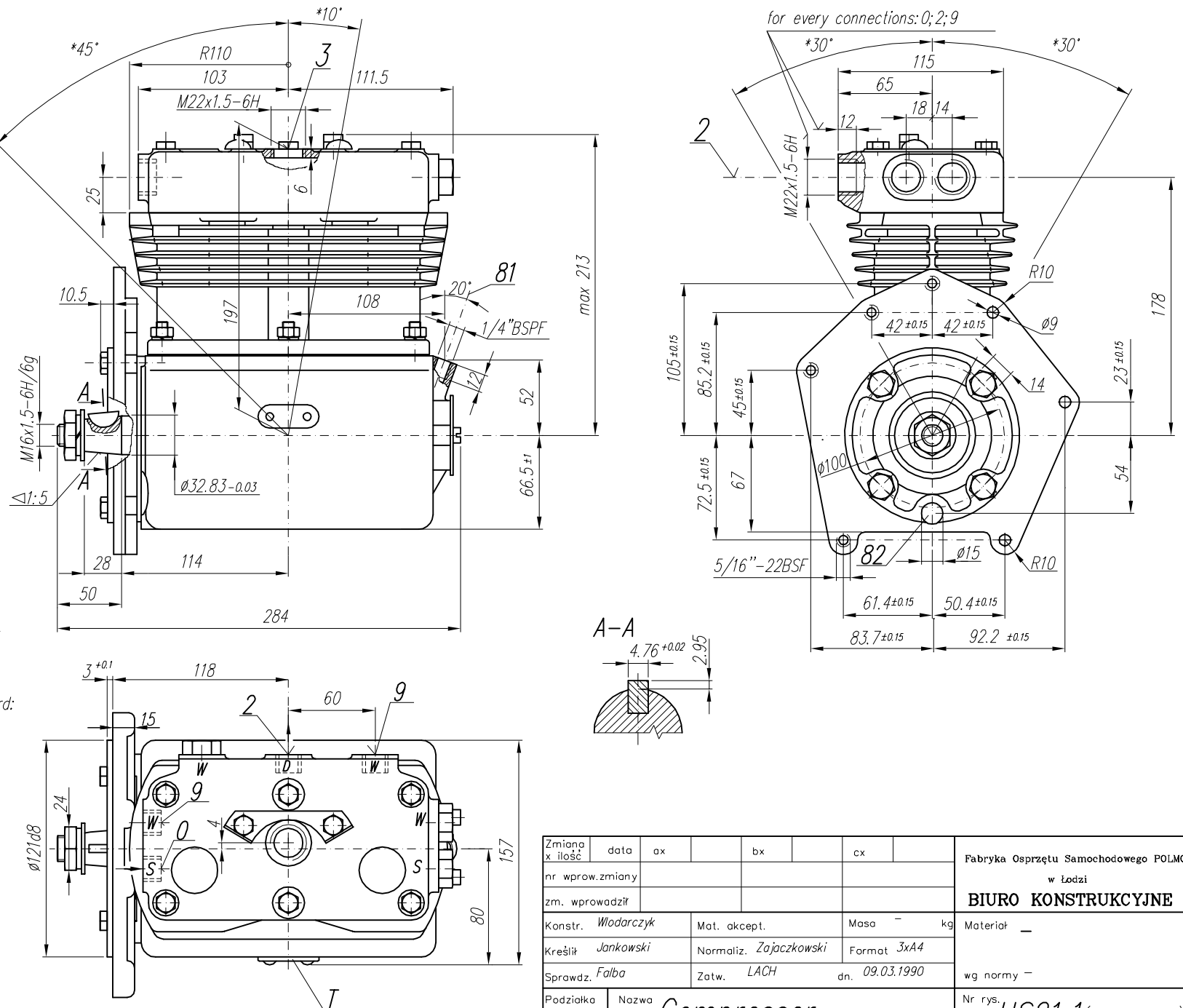

Zmiana x ilość	data	ax	bx	cx	Fabryka Osprzętu Samochodowego POLMO w Łodzi
nr. wprowadz. zmiany					BIURO KONSTRUKCYJNE
zm. wprowadził					Materiał
Konstr. Włodarczyk	Mat. akcept.		Masa - kg		
Kreślił Jankowski	Normaliz. Zajaczkowski		Format 3xA4		
Sprawdz. Falba	Zatw. LACH		dn. 09.03.1990		wg normy -
Podziałka 1:2.5	Nazwa Compressor				Nr rys. HS21.1(602.04.902)