

Suction capacity

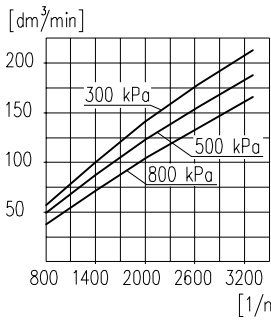

Power consumption

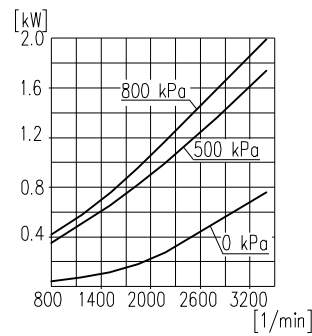

Time to fill a tank of 40dm³ capacity

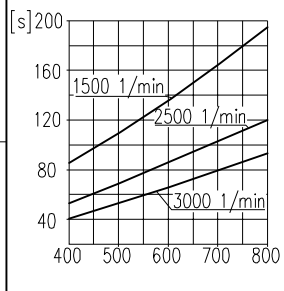

Max. r.p.m. for continuous duty

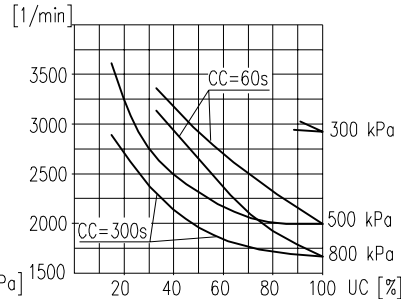

TECHNICAL DATA:

Number of cylinders 1
 Cylinder diameter 60 mm
 Piston stroke 36 mm
 Total piston displacement 100 cm³
 Mass 8,4 kg
 Working pressure 800 kPa
 Max. pressure for short time duty 1000 kPa
 Max. allowable temp. of compressed air +220 °C
 Cooling by inflation of, air with the speed of the stream min. 4 m/s
 Lubrication forced circulation, splash lubrication
 min. pressure of oil 300±200 kPa
 (The pressure drop down is allowed to min. 60 kPa during the idle running of the heated up engine)
 Normal speed max. 3000 1/min
 Max. speed, temporary 3300 1/min

SYMBOLS DESCRIPTION:

0-suction connection
 2-discharge connection
 81-lubricating oil inlet
 82-lubricating oil outlet and crankcase breathing

Digital marking according to International Standard ISO-6786

*-max. angular tilt of the compressor

T-Datum plate

** - Stopped by plug

$\alpha, \beta, \delta, \gamma$ - max. angular deflection of the compressor

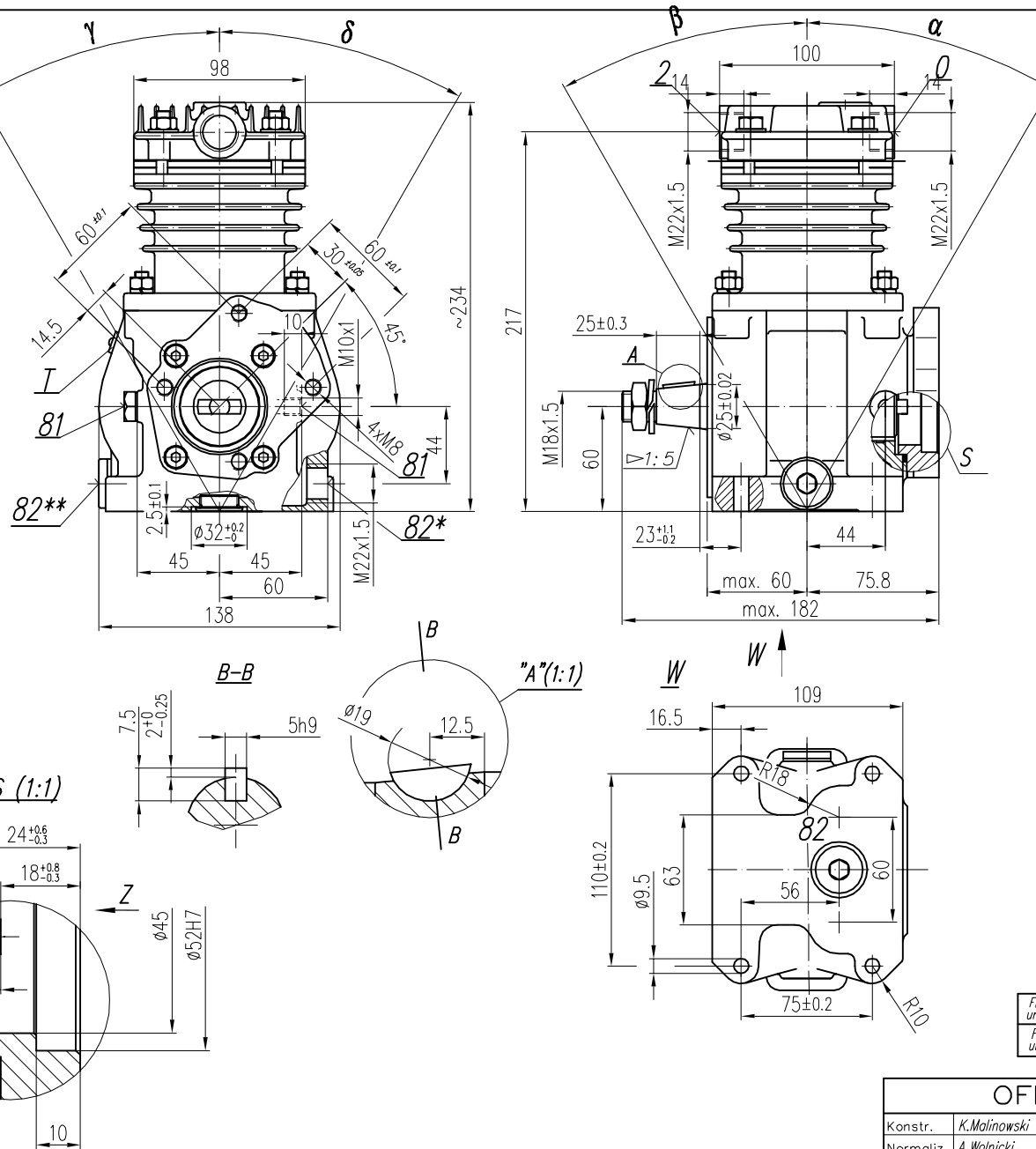

Compressor variants	
Scheme	Variant number
	601.35.961 601.35.971* 601.35.981**
	601.35.962 601.35.972* 601.35.982**
	601.35.963 601.35.973* 601.35.983**
	601.35.964 601.35.974* 601.35.984**
	601.35.965 601.35.975* 601.35.985**
	601.35.966 601.35.976* 601.35.986**
	601.35.967 601.35.977* 601.35.987**
	601.35.968 601.35.978* 601.35.988**

Numern	α	β	γ	δ
ohne Stern	20°	20°	30°	30°
Für 601.35.971-974 und 601.35.985-988	20°	20°	15°	45°
Für 601.35.981-984 und 601.35.975-978	20°	20°	45°	15°

Description
 2 Discharge port
 0 Suction port
 Oil inlet (81)

Variant nr without * - 82 at the bottom
 Variant nr with * - 82 and 81 on the same side
 Variant nr with ** - 82 and 81 on the opposite side

NOTE! The above characteristics are for open-inlet-valve control system at minimum cooling requirements and at ambient temperature +20°C

DEFINITIONS: CC=CT+CL - period of average operating cycle

$UC = \frac{CT}{CC} \times 100\%$ - percent ratio of compressor full load operating time in average operating cycle (also called percent duty cycle)

CL - compressor no-load operating time (exhaust to the atmosphere)

CT - compressor full load operating time

GENERAL TOLERANCES				
CLASS	RANGE OF NOMINAL DIMENSIONS (±)MM			
	≤50	>50 ≤180	>180 ≤400	>400
II	1.0	2.0	3.0	4.0

FORCE, POWER PRESSURE ETC.	
<	±3*
>	±10 %

OFFER DRAWING			
Konstr.	K.Malinowski	25.02.2010	FABRYKA OSPRZĘTU SAMOCHODOWEGO
Normaliz.	A.Walnicky		POLMO-Łódź S.A. FOS Stuzba Rozwoju
Sprawdzit	A.Walnicky		
Zatwierdzit	A.Walnicky		
Podziatka	Nazwa	1:2.5 Compressor 601.35.971	