

Suction capacity

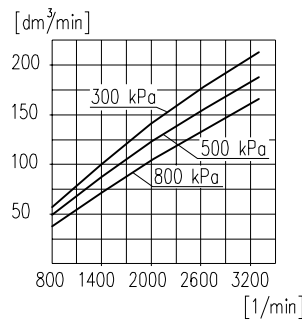

Power consumption

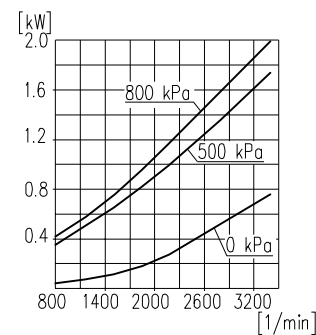

Time to fill a tank of 40dm³ capacity

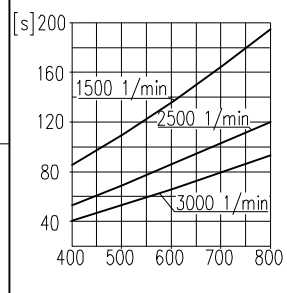

Max. r.p.m. for continuous duty

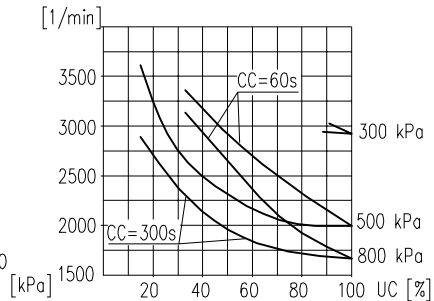

TECHNICAL DATA:

Number of cylinders 1
 Cylinder diameter 60 mm
 Piston stroke 36 mm
 Total piston displacement 100 cm³
 Mass 8,4 kg
 Working pressure 800 kPa
 Max. pressure for short time duty 1000 kPa
 Max. allowable temp. of compressed air +220 °C
 Cooling by inflation of, air with the speed of the stream min. 4 m/s
 Lubrication forced circulation, splash lubrication
 min. pressure of oil 300±200 kPa
 (The pressure drop down is allowed to min. 60 kPa during the idle running of the heated up engine)
 Normal speed max. 3000 1/min
 Max. speed, temporary 3300 1/min

SYMBOLS DESCRIPTION:

0-suction connection
 2-discharge connection
 81-lubricating oil inlet
 82-lubricating oil outlet and crankcase breathing

Digital marking according to International Standard ISO-6786
 *-max. angular tilt of the compressor
 T-Datum plate
 ** - Stoped by plug
 * - max. angular deflection of the compressor

NOTE! The above characteristics are for open-inlet-valve control system at minimum cooling requirements and at ambient temperature +20°C

DEFINITIONS: CC=CT+CL - period of average operating cycle

$UC = \frac{CT}{CC} \times 100\%$ - percent ratio of compressor full load operating time in average operating cycle(also called percent duty cycle)

CL - compressor no-load operating time (exhaust to the atmosphere)

CT - compressor full load operating time

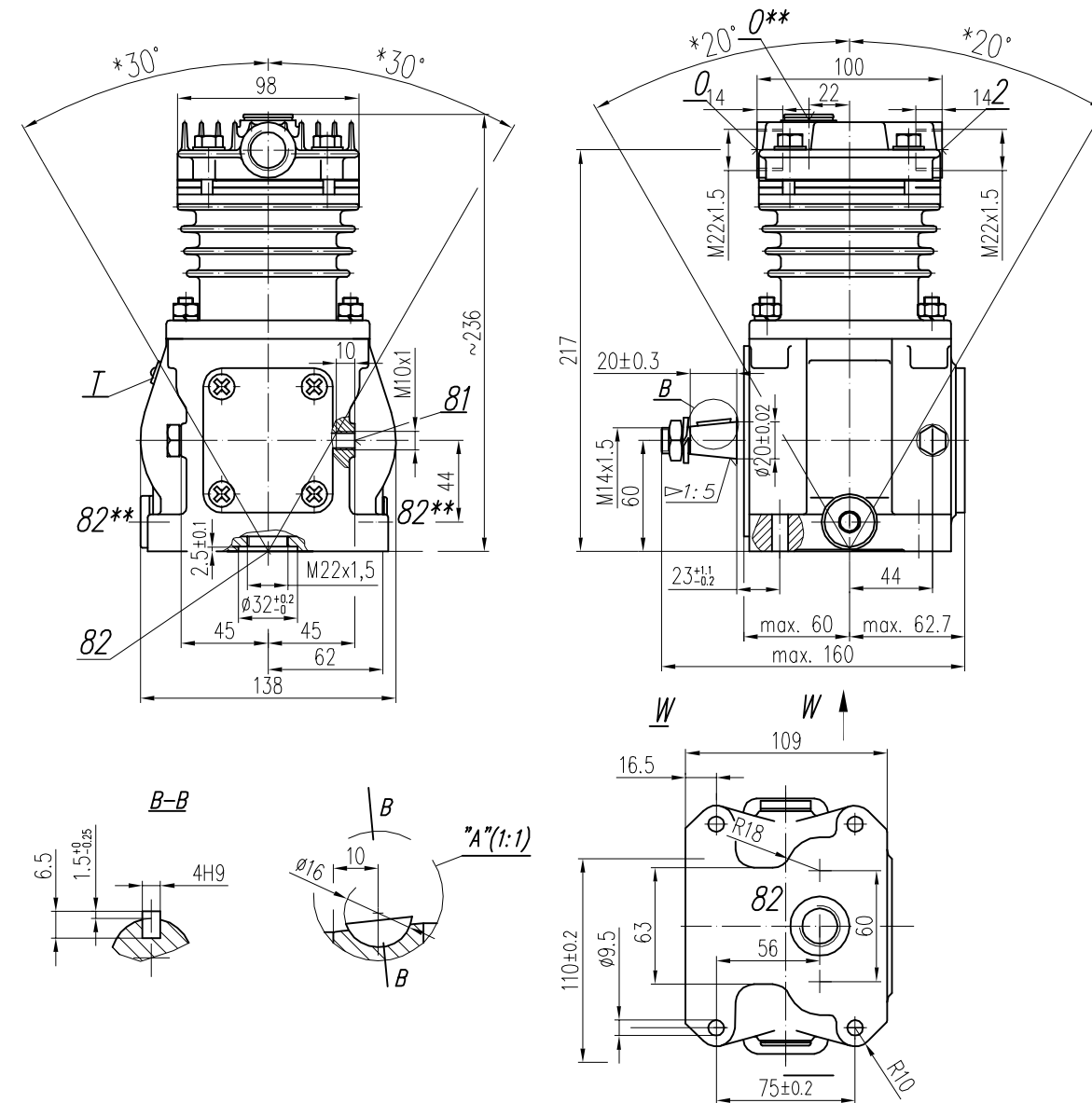

OFFER DRAWING			
Konstr.	K.Malinowski	25.02.2010	FABRYKA OSPRZĘTU SAMOCHODOWEGO
Normaliz.	A.Walnicki		POLMO-Łódź S.A. FOS Stuzba Rozwoju
Sprawdzit	A.Walnicki		
Zatwierdził	A.Walnicki		
Podziałka	Nazwa	1:2.5 Compressor 601.35.935	

GENERAL TOLERANCES				
CLASS	RANGE OF NOMINAL DIMENSIONS (±)MM			
	≤50	>50 ≤180	>180 ≤400	≥400
II	1.0	2.0	3.0	4.0
	±3*			
	±10 %			