

TECHNICAL DATA:

Number of cylinders 1
 Cylinder diameter 60 mm
 Piston stroke 36 mm
 Total piston displacement 100 cm³
 Mass 8,4 kg
 Working pressure 800 kPa
 Max. pressure for short time duty 1000 kPa
 Max. allowable temp. of compressed air +220 °C
 Cooling by inflation of, air with the speed of the stream min. 4 m/s
 Lubrication forced circulation, splash lubrication
 min. pressure of oil 300±200 kPa
 (The pressure drop down is allowed to min. 60 kPa during the idle running of the heated up engine)
 Normal speed max. 3000 1/min
 Max. speed, temporary 3300 1/min

SYMBOLS DESCRIPTION:

0-suction connection
 2-discharge connection
 81-lubricating oil inlet
 82-lubricating oil outlet and crankcase breathing
 Digital marking according to International Standard ISO-6786
 *-max. angular tilt of the compressor
 T-Datum plate
 ** - Stopped by plug
 α, β, δ, γ - max. angular deflection of the compressor

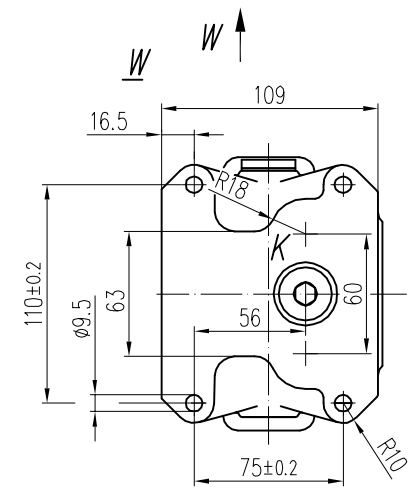
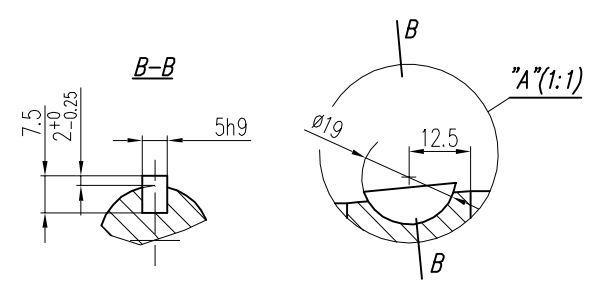
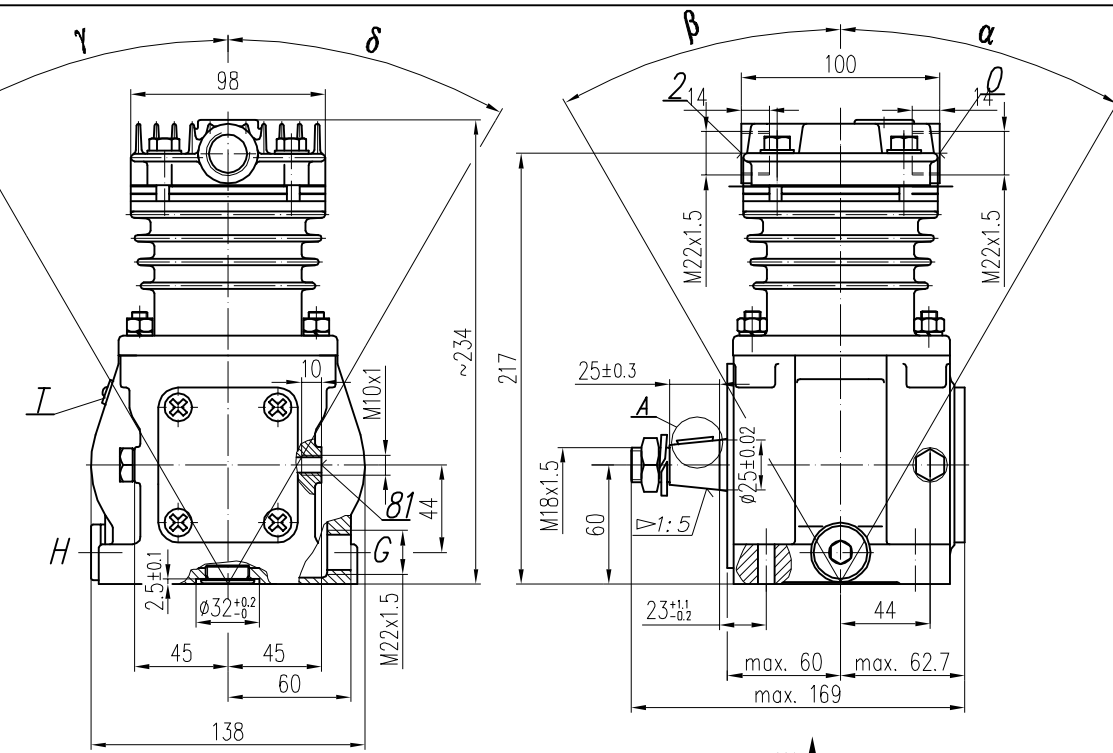

Compressor variants	
Scheme	Variant number
	601.35.901 601.35.911* 601.35.921**
	601.35.902 601.35.912* 601.35.922**
	601.35.903 601.35.913* 601.35.923**
	601.35.904 601.35.914* 601.35.924**

Variant nr without * - 82 at the bottom, 81 position X
 Variant nr with * - 82 and 81 position X
 Variant nr with ** - 82 and 81 position Y

	Description
	Discharge port
	Suction port

NOTE! The above characteristics are for open-inlet-valve control system at minimum cooling requirements and at ambient temperature +20°C

DEFINITIONS: CC=CT+CL - period of average operating cycle

$UC = \frac{CT}{CC} \times 100\%$ - percent ratio of compressor full load operating time in average operating cycle (also called percent duty cycle)
 CL - compressor no-load operating time (exhaust to the atmosphere)
 CT - compressor full load operating time

Port 82 position	α	β	γ	δ
G	20°	20°	15°	45°
H	20°	20°	45°	15°
K	20°	20°	30°	30°

GENERAL TOLERANCES				
CLASS	RANGE OF NOMINAL DIMENSIONS (±)MM			
	≤50	>50 ≤180	>180 ≤400	>400
II	1.0	2.0	3.0	4.0

FORCE, POWER PRESSURE ETC.	±3*	±10 %
----------------------------	-----	-------

OFFER DRAWING			
Konstr.	K.Malinowski	25.02.2010	FABRYKA OSPRZĘTU SAMOCHODOWEGO
Normaliz.	A.Walnicki		POLMO-KÓDZ S.A. FOS Stuzba Rozwoju
Sprawdzit	A.Walnicki		
Zatwierdził	A.Walnicki		
Podziałka	Nazwa	1:2.5 Compressor 601.35.911	