

Suction capacity
[dm³/min]

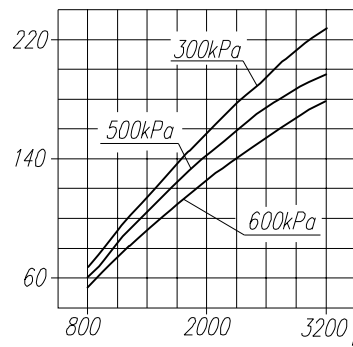

Power consumption
[kW]

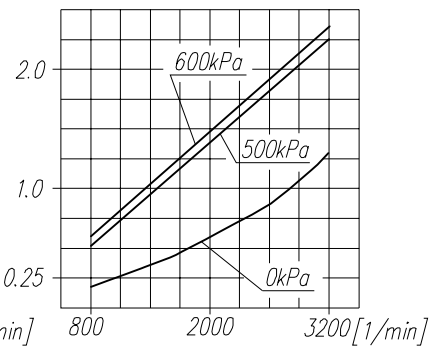

Time to fill a tank of 40dm³ capacity
[S]

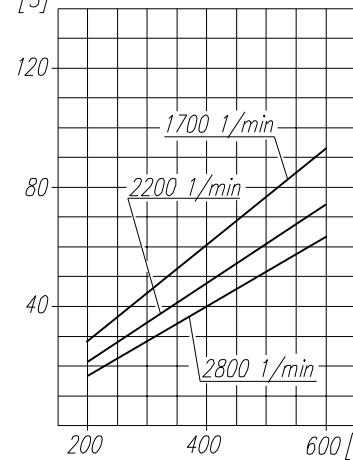

Max. r.p.m. for continuous duty
[1/min]

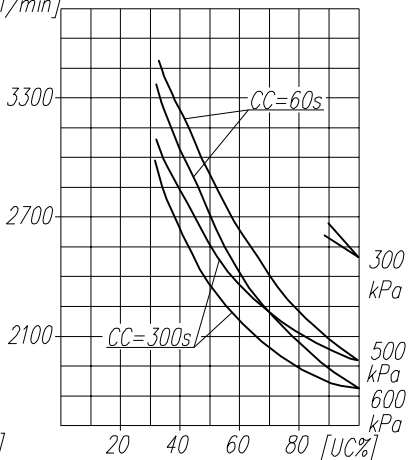

TECHNICAL DATA:

Number of cylinders 1
 Cylinder diameter 60 mm
 Piston stroke 40 mm
 Total piston displacement 11.3 cm³
 Mass 11.2 kg
 Working pressure 800 kPa
 Max. pressure for short time duty 1000 kPa
 Max. allowable temp. of compressed air +220 °C
 Cooling by inflation of air, with the speed of the stream min. 4m/s
 Lubrication fog of the oil from engine

SYMBOLS DESCRIPTION:

0 - suction connection
 2 - discharge connection
 Numeral signs according to International Standard ISO-6786
 T - rating plate
 S - The checking hole of lubrication blind with screw M6

NOTE! The above characteristics are for open-inlet-valve control system at minimum cooling requirements and at ambient temperature of +20°C

DEFINITIONS: CC=CT+CL - period of average operating cycle

$UC = \frac{CT}{CC} \times 100\%$ - percent ratio of compressor full load operating time in average operating cycle (also called percent duty cycle)

CL - compressor no-load operating time (exhaust to the atmosphere)

CT - compressor full load operating time

Variants of compressor	
601.26.915	acc. drawing
601.26.916	without belt guard P
601.26.917	without of the terminal K

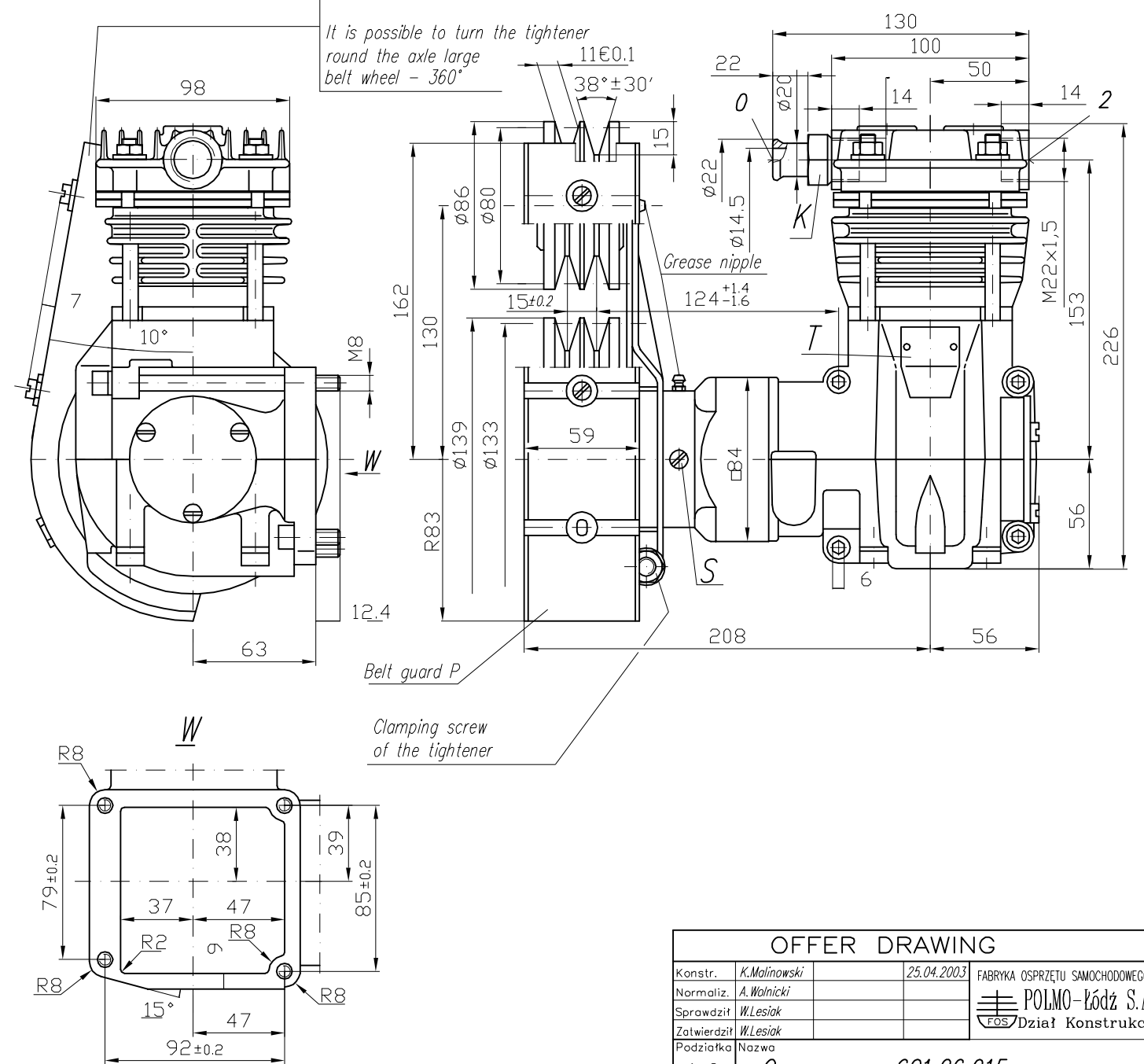

OFFER DRAWING			
Konstr.	K.Malinowski	25.04.2003	FABRYKA OSPRZĘTU SAMOCHODOWEGO
Normaliz.	A.Walnicki		POLMO-KÓDZ S.A. FOS Dział Konstrukcji
Sprawdził	W.Lesiak		
Zatwierdził	W.Lesiak		
Podziałka	Nazwa	1:2 Compressor 601.26.915	