

Suction capacity
[dm³/min]

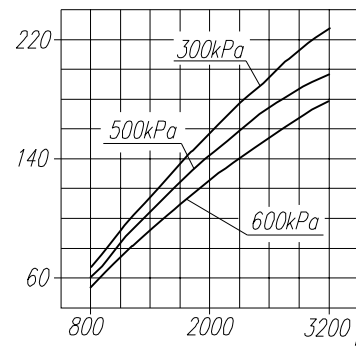

Power consumption
[kW]

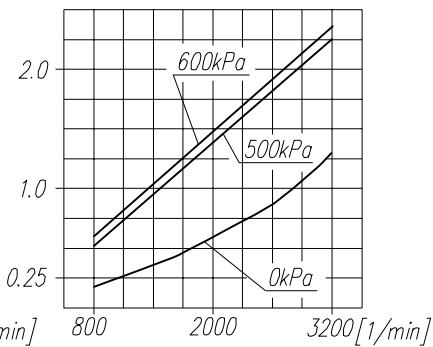

TECHNICAL DATA:

Number of cylinders	1
Cylinder diameter	60 mm
Piston stroke	40 mm
Total piston displacement	11.3 cm ³
Mass	11.2 kg
Working pressure	800 kPa
Max. pressure for short time duty	1000 kPa
Max. allowable temp. of compressed air	+220 °C
Cooling by inflation of air, with the speed of the stream min.	4m/s

Lubrication fog of the oil from engine

Time to fill a tank of 40dm³
capacity
[S]

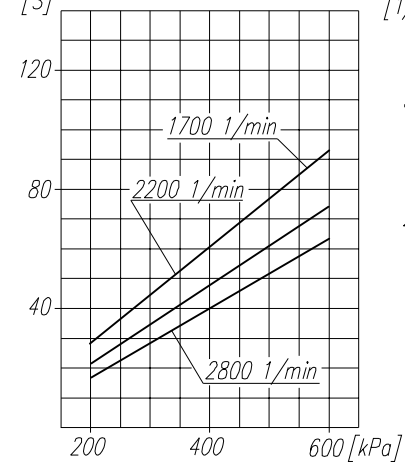

Max. r.p.m. for continuous duty
[1/min]

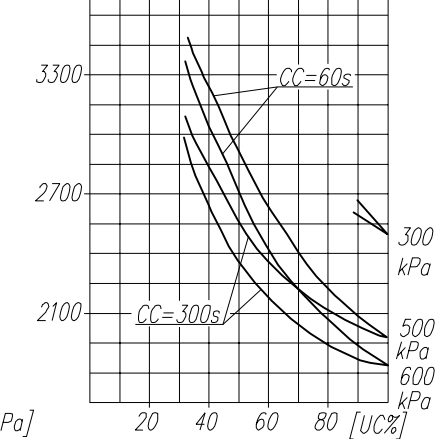

SYMBOLS DESCRIPTION:

- 0 - suction connection
 - 2 - discharge connection
- Numeral signs according to International Standard ISO-6786
- T - rating plate
 - S - The checking hole of lubrication blind with screw M6

NOTE! The above characteristics are for open-inlet-valve control system at minimum cooling requirements and at ambient temperature of +20°C

DEFINITIONS: $CC=CT+CL$ - period of average operating cycle

$UC = \frac{CT}{CC} \times 100\%$ - percent ratio of compressor full load operating time in average operating cycle (also called percent duty cycle)

CL - compressor no-load operating time (exhaust to the atmosphere)

CT - compressor full load operating time

