

Time to fill a tank of 40dm³ capacity

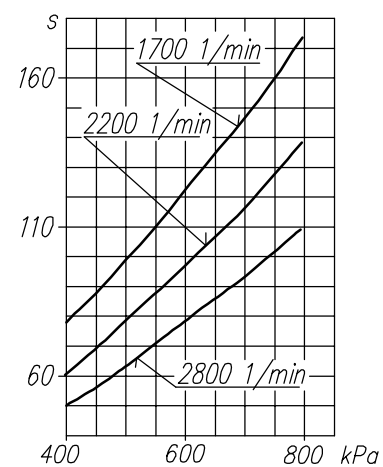

Max. r.p.m. for continuous duty

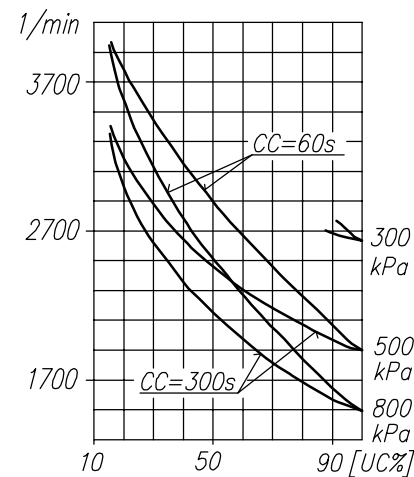

TECHNICAL DATA:

Number of cylinders 1
 Cylinder diameter 60 mm
 Piston stroke 38 mm
 Total piston displacement 107 cm³
 Mass kg
 Working pressure 800 kPa
 Max. pressure for short time duty 1000 kPa
 Max. allowable temp. of compressed air +220 °C
 Cooling by inflation of air, with the speed of the stream min. 4m/s
 Lubrication: individual splash lubrication with motor oil poured into the crankcase; oil volume about 140 cm³

SYMBOLS DESCRIPTION:

0 - suction connection
 2 - discharge connection
 3 - breather
 81 - oil inlet
 82 - oil outlet
 Numeral signs according to International Standard ISO-6786
 Z - compressor symbol and production date

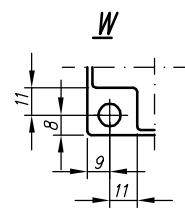
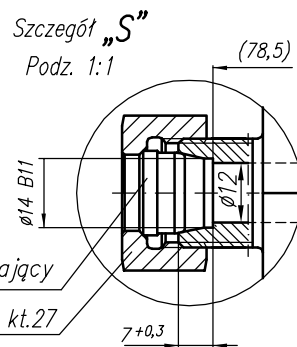
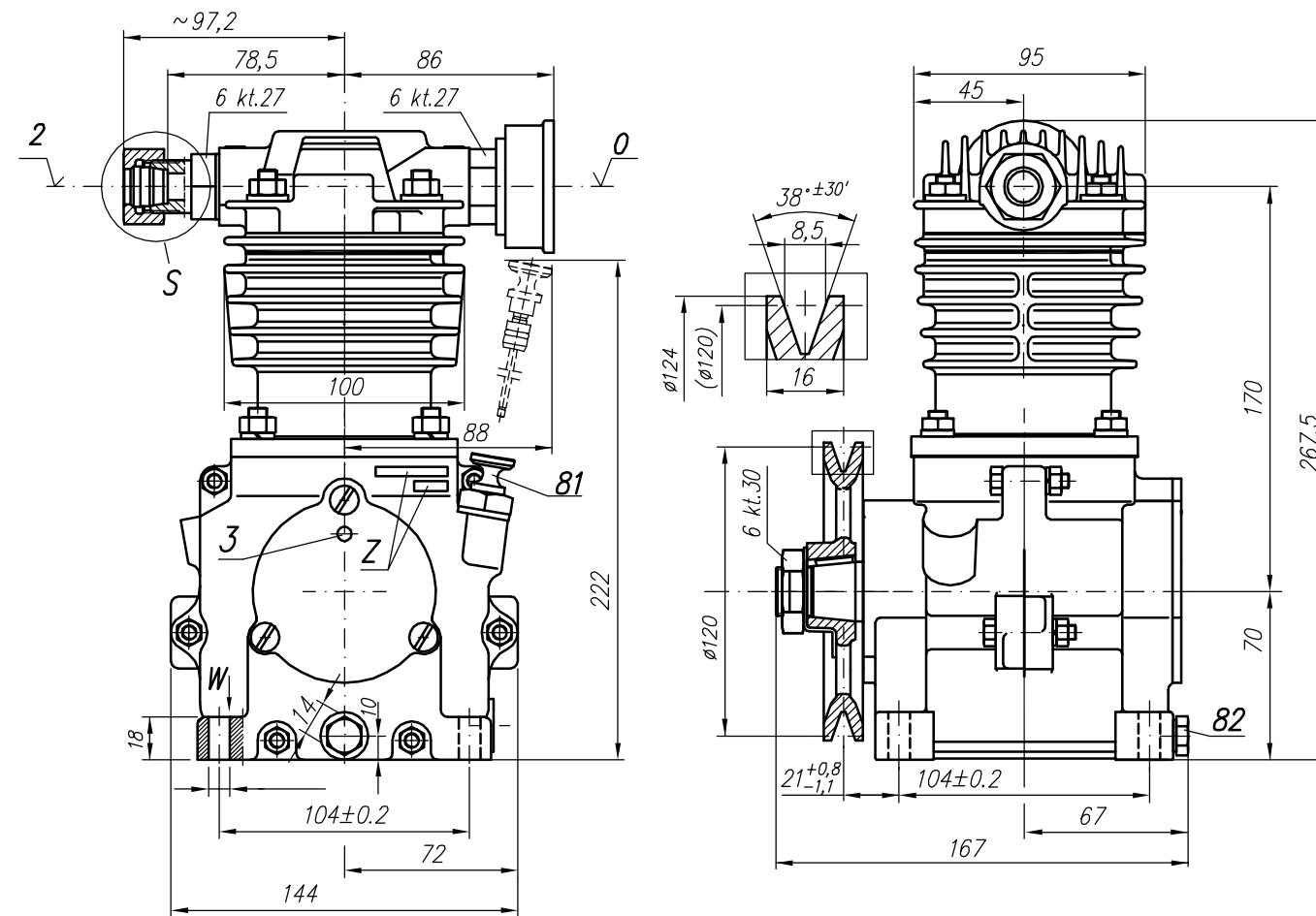

NOTE! The above characteristics are for open-inlet-valve control system at minimum cooling requirements and at ambient temperature +20°C

DEFINITIONS: CC=CT+CL - period of average operating cycle

$UC = \frac{CT}{CC} \times 100\%$ - percent ratio of compressor full load operating time in average operating cycle (also called percent duty cycle)
 CL - compressor no-load operating time (exhaust to the atmosphere)
 CT - compressor full load operating time

OFFER DRAWING			
Konstr.	Włodarczyk	3.01.97 r.	FABRYKA OSPRZĘTU SAMOCHODOWEGO
Normaliz.	L. Baryna		POLMO-Łódź S.A. Dział Konstrukcji
Sprawdził	W. Lesiak		
Zatwierdził	W. Antkowiak		
Podziałka	Nazwa	1:2 Compressor 601.23.936	