

Suction capacity

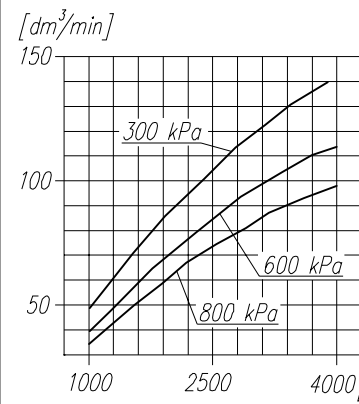

Power consumption

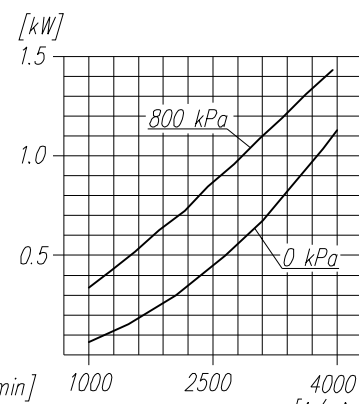

Time to fill a tank of 10dm³ capacity

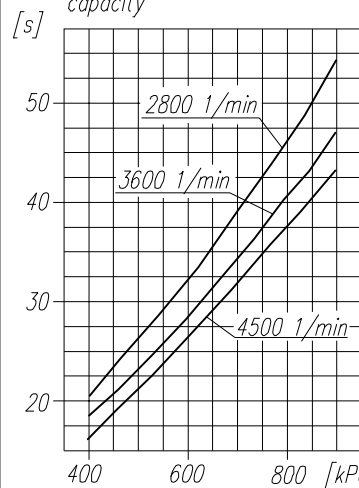

Max. r.p.m. for continuous duty capacity

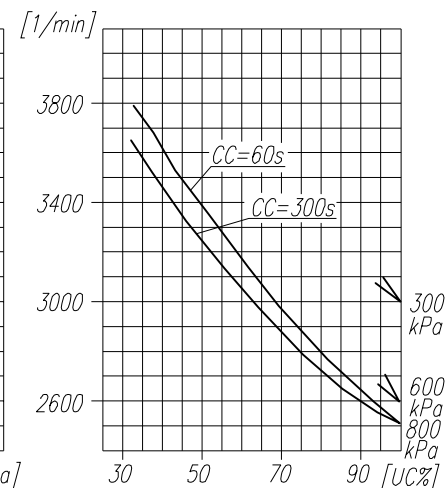

NOTE! The above characteristics are for open-inlet-valve control system at minimum cooling requirements and at ambient temperature +20°C

DEFINITIONS: $CC=CT+CL$ - period of average operating cycle

$UC = \frac{CT}{CC} \times 100\%$ - percent ratio of compressor full load operating time in average operating cycle (also called percent duty cycle)

CL - compressor no-load operating time (exhaust to the atmosphere)

CT - compressor full load operating time

TECHNICAL DATA:

- Number of cylinders - 1
- Cylinder diameter - 65 mm
- Piston stroke - 23 mm
- Total piston displacement - 76 cm³
- Mass - 10 kg
- Working pressure - 800 kPa
- Max. pressure for short time duty - 1000 kPa
- Max. allowable temp. of compressed air - +220 °C
- Cooling by inflation of air, with the speed of the stream min. 4m/s
- Lubrication forced circulation, splash lubrication min. pressure of oil 200kPa

SYMBOLS DESCRIPTION:

- 0 - suction connection
- 2 - discharge connection
- 81 - lubricating oil inlet
- 82 - lubricating oil outlet and crankcase breathing
- Numeral signs according to "International Standard ISO-6786"
- T - rating plate
- * - max. angular deflection of the compressor

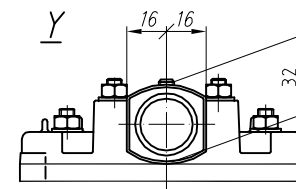
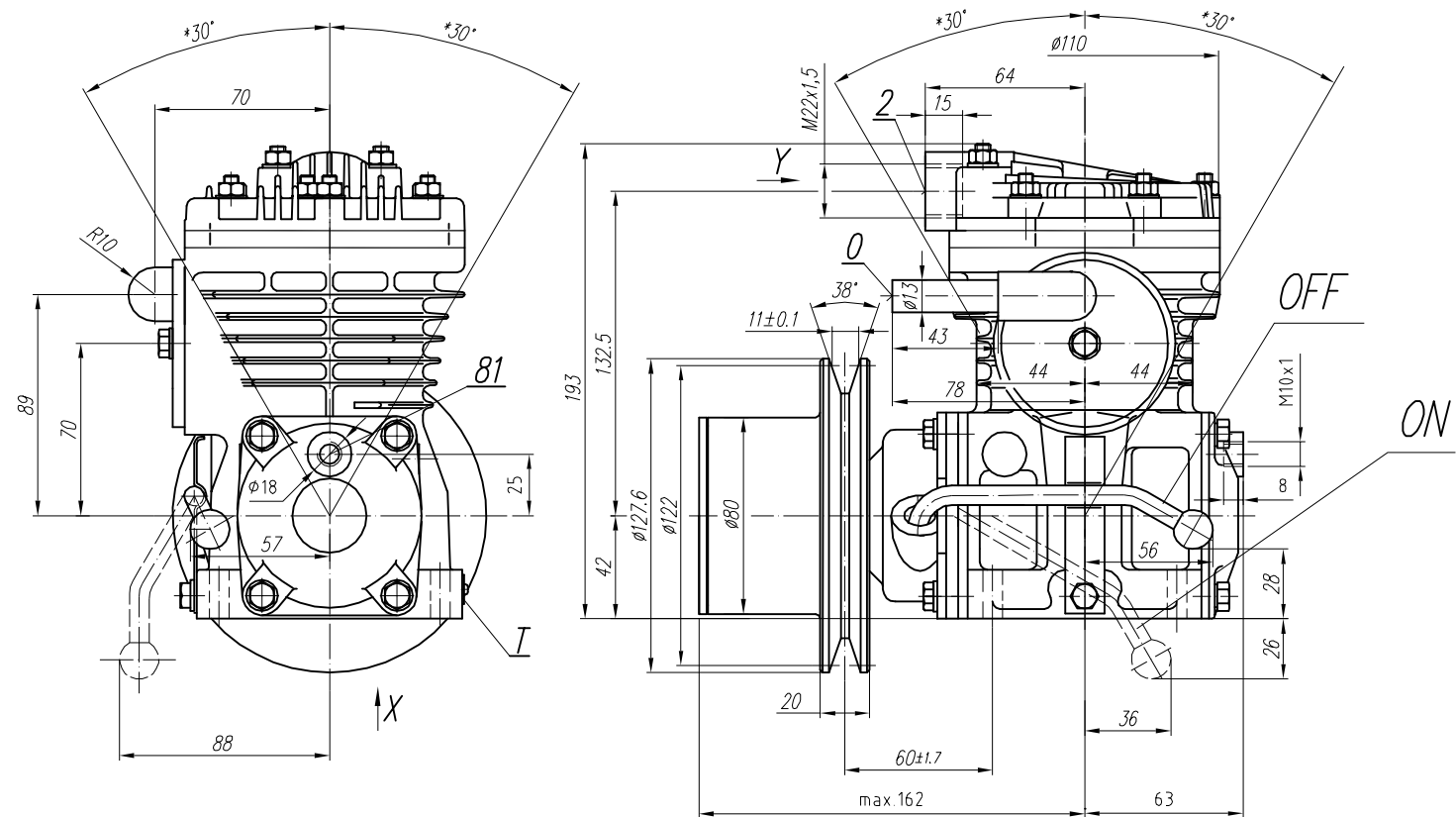
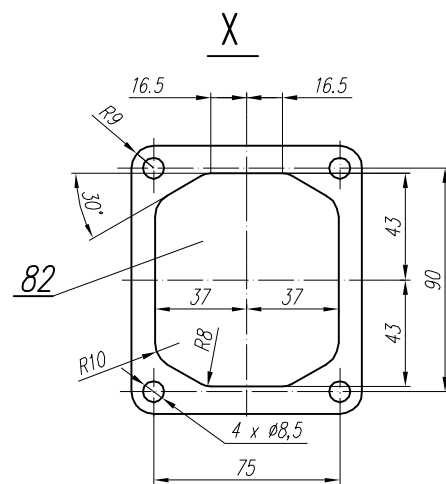

CLASS	GENERAL TOLERANCES				FORCE, POWER PRESSURE ETC.
	RANGE OF NOMINAL DIMENSIONS (±)MM				
II	≤50	>50 ≤180	>180 ≤400	≥400	±3* ±10 %

OFFER DRAWING			
Konstr.	J.Ustyniak	29.08.2005	FABRYKA OSPRZĘTU SAMOCHODOWEGO
Normaliz.	A.Walnicki		POLMO-KÓDZ S.A. Dział Konstrukcji
Sprawdził	A.Walnicki		
Zatwierdził	A.Walnicki		
Podziałka	Nazwa	1:2 Compressor 601.17.981	