

Suction capacity

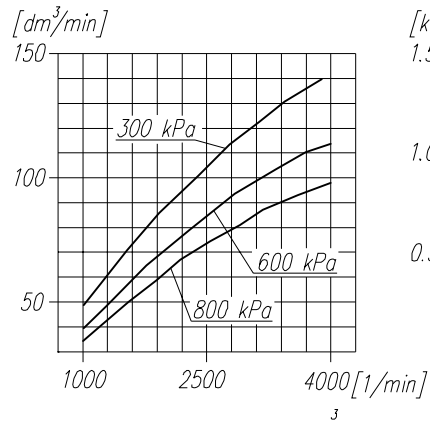

Power consumption

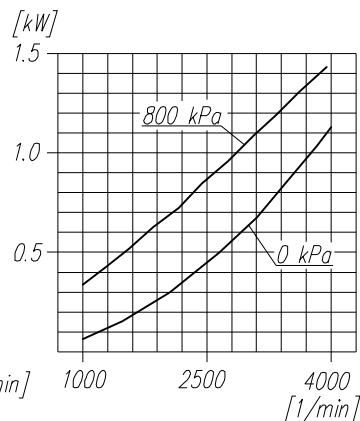

Time to fill a tank of 10dm capacity

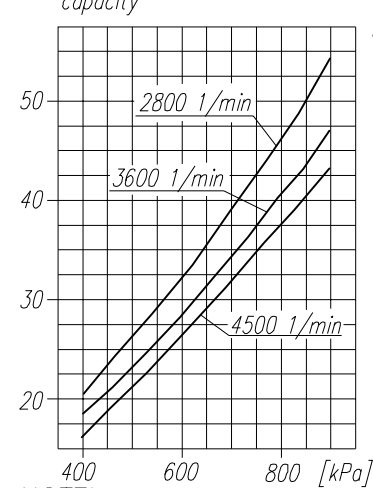

Max. r.p.m. for continuous duty

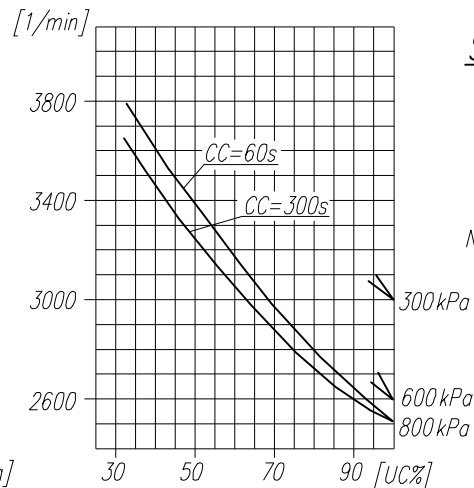

NOTE! The above characteristics are for open-inlet-valve control system at minimum cooling requirements and at ambient temperature +20°C

DEFINITIONS: $CC=CT+CL$ - period of average operating cycle

$UC = \frac{CT}{CC} \times 100\%$ - percent ratio of compressor full load operating time in average operating cycle (also called percent duty cycle)

CL - compressor no-load operating time (exhaust to the atmosphere)

CT - compressor full load operating time

TECHNICAL DATA:

Number of cylinders 1
 Cylinder diameter 65 mm
 Piston stroke 23 mm
 Total piston displacement 76 cm³
 Mass 8,5 kg
 Working pressure 800 kPa
 Max. pressure for short time duty 1000 kPa
 Max. allowable temp. of compressed air +220 °C
 Cooling by inflation of air, with the speed of the stream min. 4 m/s
 Lubrication forced circulation, splash lubrication
 min. pressure of oil 300±200 kPa
 (The pressure drop down is allowed to min. 60 kPa during the idle running of the heated up engine)

SYMBOLS DESCRIPTION:

0 - suction connection
 2 - discharge connection
 81 - lubricating oil inlet
 82 - lubricating oil outlet and crankcase breathing
 Numeral signs according to "International Standard ISO-6786"
 T - rating plate
 * - max. angular deflection of the compressor

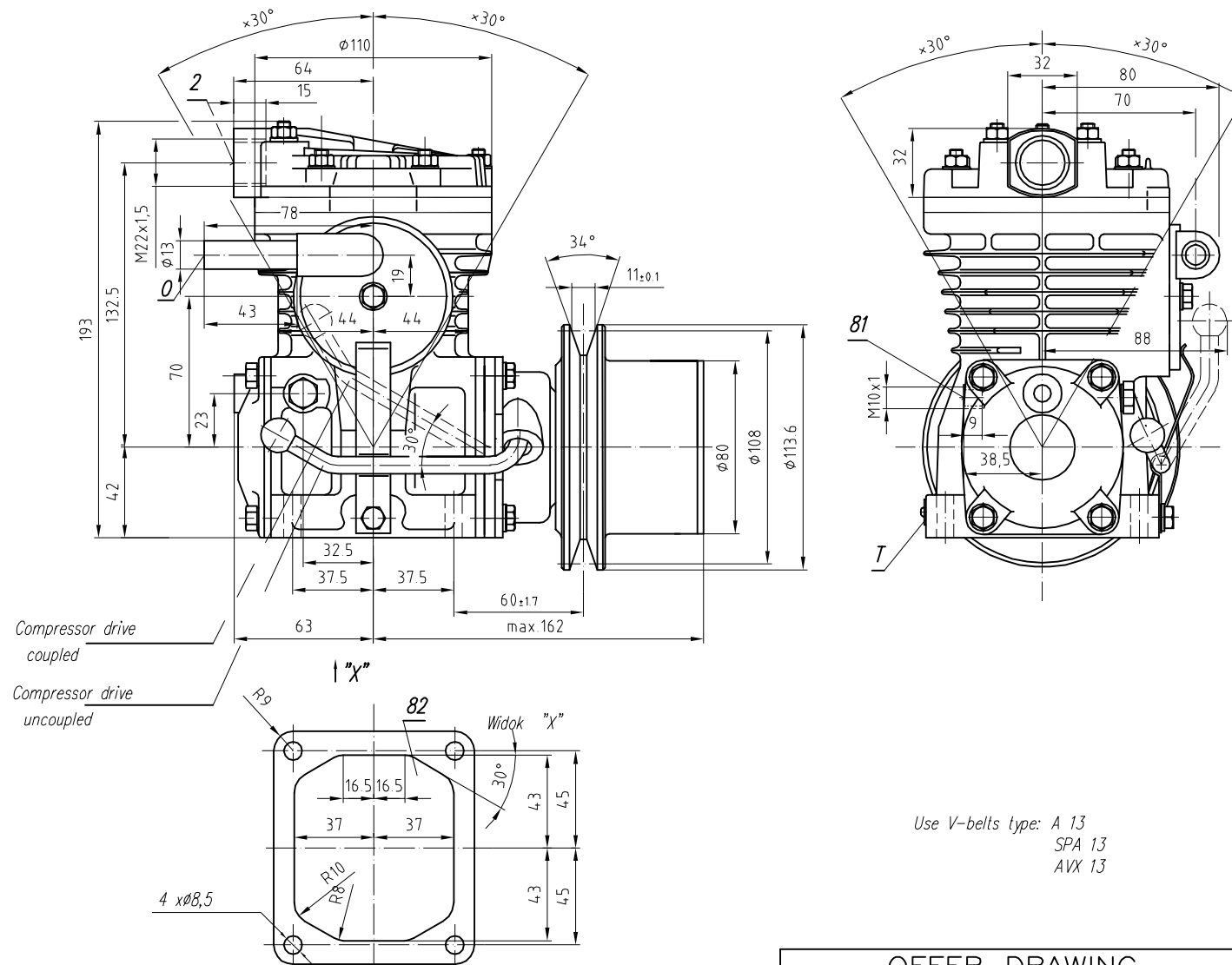

Use V-belts type: A 13
 SPA 13
 AVX 13

GENERAL TOLERANCES				
CLASS	RANGE OF NOMINAL DIMENSIONS (±)MM			
	≤50	>50 ≤180	>180 ≤400	≥400
II	1.0	2.0	3.0	4.0

FORCE, POWER PRESSURE ETC.	
∇	±3*
∇	±10 %

OFFER DRAWING			
Konstr.	K.Malinowski	09.07.2004	FABRYKA OSPRZĘTU SAMOCHODOWEGO
Normaliz.	A.Walnicki		POLMO-KÓDZ S.A.
Sprawdzit	W.Lesiak		
Zatwierdził	W.Lesiak		
Podziałka	Nazwa	1:2 Compressor 601.17.978	