

TECHNICAL DATA:

Number of cylinders 1
 Cylinder diameter 65 mm
 Piston stroke 23 mm
 Total piston displacement 76 cm³
 Mass 7.2 kg
 Working pressure to 800 kPa
 Max. pressure for short time duty 900 kPa
 Max. allowable temp. of compressed air +220 °C
 Normal speed max. 3000 1/min
 Cooling by inflation of air, with the speed of the stream min. 4 m/s
 Lubrication forced circulation, splash lubrication
 min. pressure of oil 200 kPa

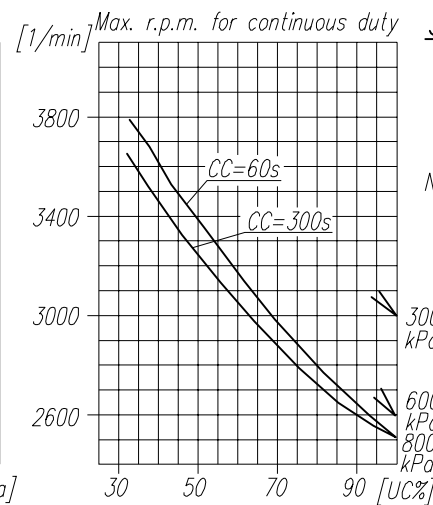
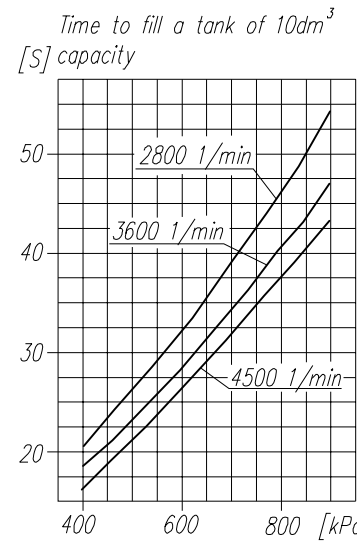

SYMBOLS DESCRIPTION:

0 - suction connection
 2 - discharge connection
 81 - lubricating oil inlet
 82 - lubricating oil outlet and crankcase breathing
 Numerical signs according to International Standard ISO-6786
 T - rating plate
 * - max. angular deflection of the compressor

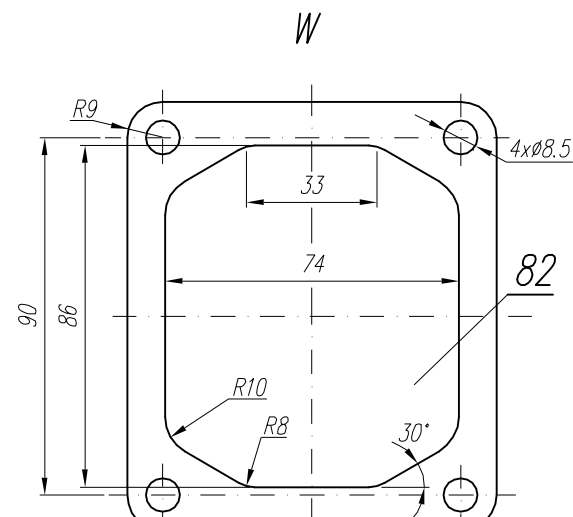
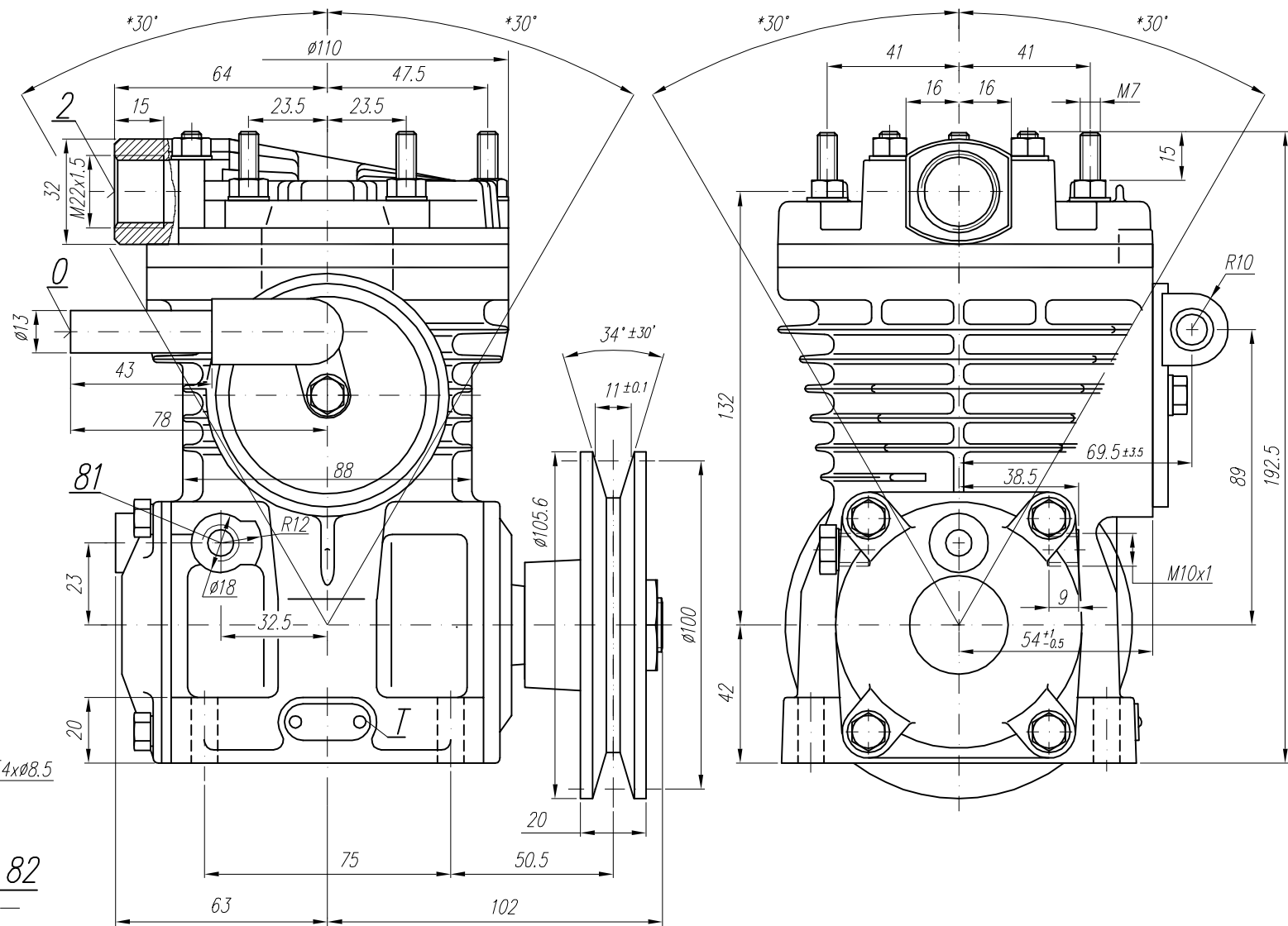

NOTE! The above characteristics are for open-inlet-valve control system at minimum cooling requirements and at ambient temperature +20°C

DEFINITIONS: $CC=CT+CL$ - period of average operating cycle
 $UC=\frac{CT}{CC} \times 100\%$ - percent ratio of compressor full load operating time in average operating cycle (also called percent duty cycle)
 CL - compressor no-load operating time (exhaust to the atmosphere)
 CT - compressor full load operating time

OFFER DRAWING			
Konstr.	K.Malinowski	20.11.2003	FABRYKA OSPRZĘTU SAMOCHODOWEGO
Normaliz.	A. Wolnicki		POLMO-Łódź S.A.
Sprawdził	W.Lesiak		
Zatwierdził	W.Lesiak		FOS Dział Konstrukcji
Podziałka	Nazwa	1:1,25 Compressor 601.17.954	