

Suction capacity

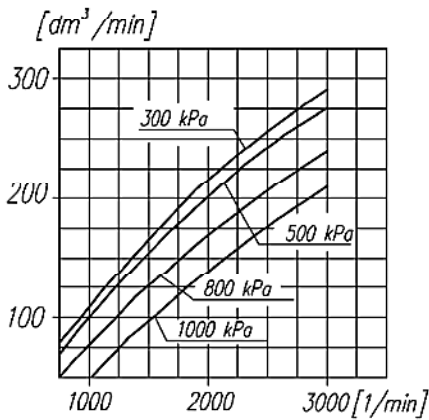

Power consumption

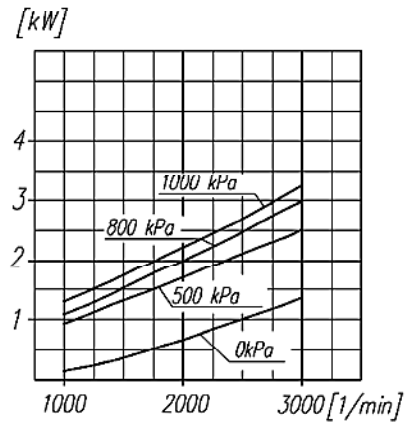

Time to fill a tank of 40dm³ capacity

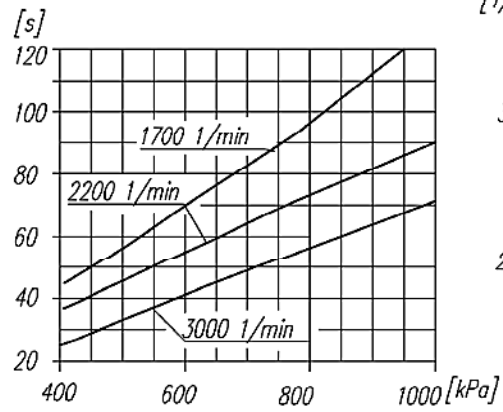

Max. r.p.m. for continuous duty

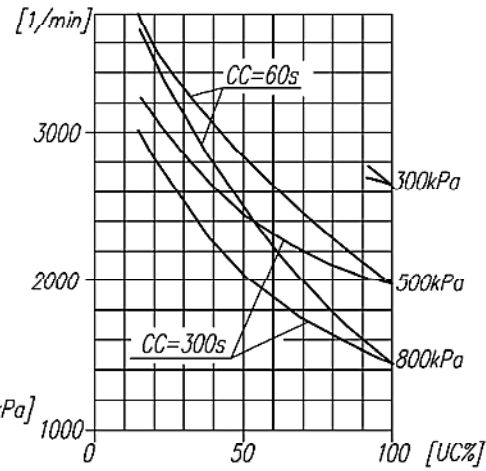

NOTE! The above characteristics are for open-inlet-valve control system at minimum cooling requirements and at ambient temperature +20°C

DEFINITIONS: CC=CT+CL - period of average operating cycle

$UC = \frac{CT}{CC} \times 100\%$ - percent ratio of compressor full load operating time in average operating cycle (also called percent duty cycle)
 CL - compressor no-load operating time (exhaust to the atmosphere)
 CT - compressor full load operating time

TECHNICAL DATA:

Number of cylinders 1
 Cylinder diameter 75 mm
 Piston stroke 36 mm
 Total piston displacement 159 cm³
 Mass 10 kg
 Working pressure 1000 kPa
 Max. pressure for short time duty 1100 kPa
 Max. allowable temp. of compressed air +220 °C
 Cooling by inflation of air, with the speed of the stream min. 6 m/s
 Lubrication forced circulation, splash lubrication
 min. pressure of oil 300±200 kPa
 (The pressure drop down is allowed to min. 60 kPa during the idle running of the heated up engine)

SYMBOLS DESCRIPTION:

0 - suction connection
 2 - discharge connection
 81 - lubricating oil inlet
 82 - lubricating oil outlet and crankcase breathing
 Numerical signs according to International Standard ISO-6786
 T - rating plate
 * - max. angular deflection of the compressor

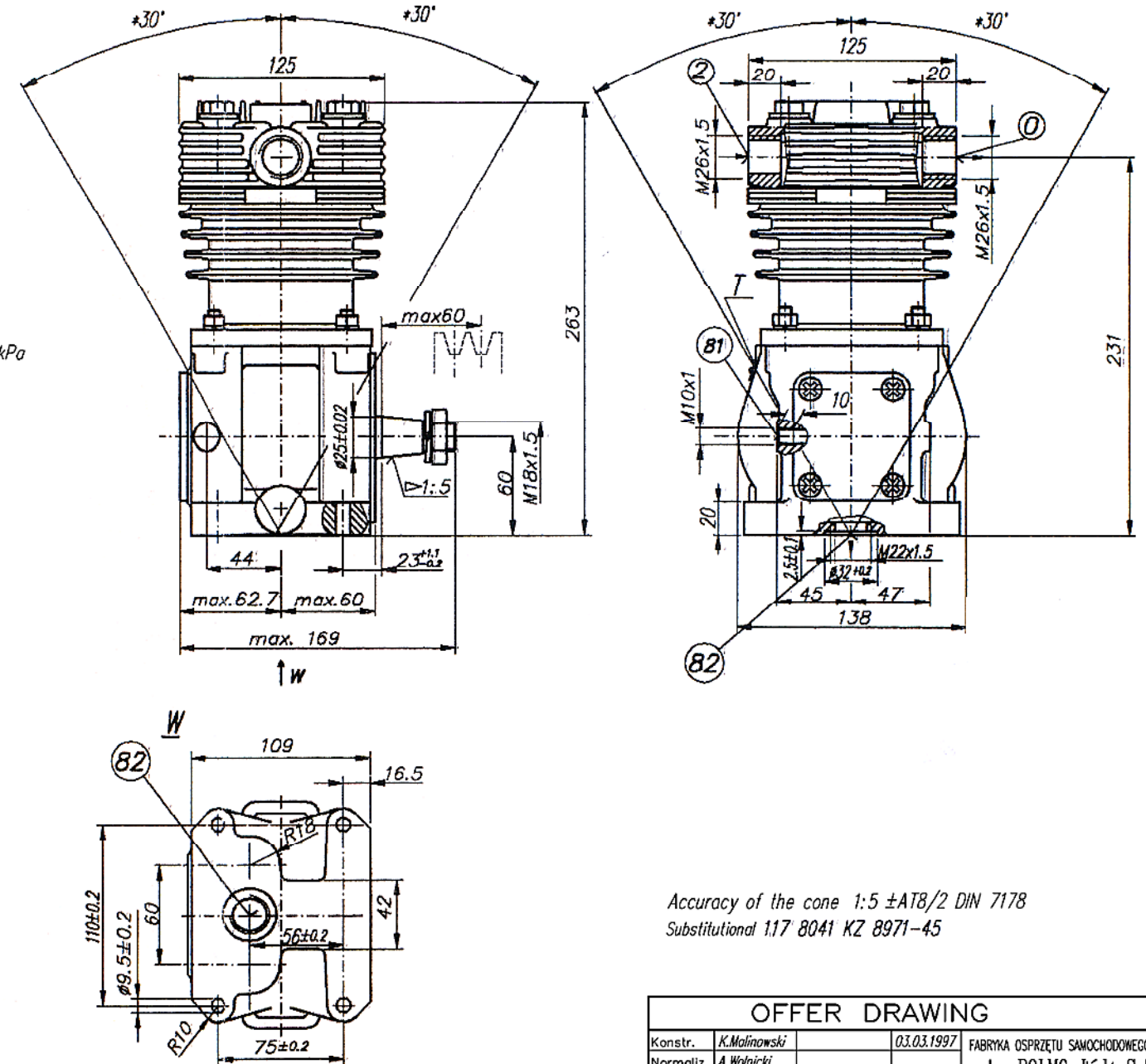

Accuracy of the cone 1:5 ±AT8/2 DIN 7178
 Substitutional 117 8041 KZ 8971-45

GENERAL TOLERANCES				
CLASS	RANGE OF NOMINAL DIMENSIONS (±)mm			
	≤50	>50 ≤180	>180 ≤400	>400
II	1.0	2.0	3.0	4.0

OFFER DRAWING			
Konstr.	K. Malinowski	03.03.1997	FABRYKA OSPRZETU SAMOCHODOWEGO
Normaliz.	A. Wahnicki		POLMO-KÓDZ S.A. Dział Konstrukcji
Sprawdzit	W. Lesiak		
Zalwierdzit	W. Lesiak		
Podziatka	Nazwa	1:2.5 Compressor 601.09.922	