

Suction capacity

[dm<sup>3</sup>/min]

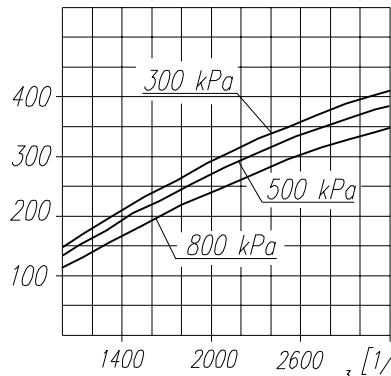

Time to fill a tank of 40dm<sup>3</sup> capacity

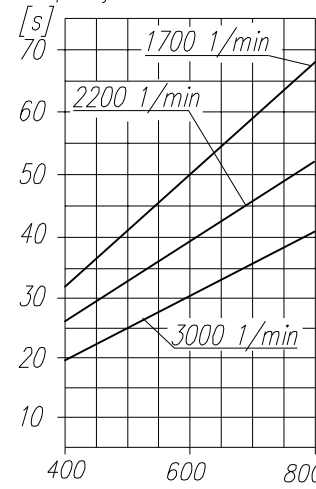

Power consumption

[kW]

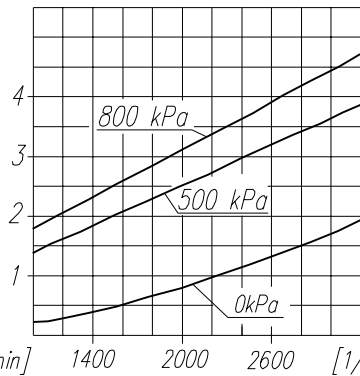

Max. r.p.m. for continuous duty

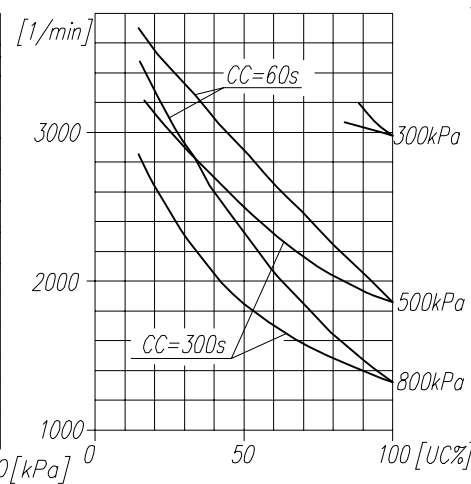

**TECHNICAL DATA:**

Number of cylinders 1  
 Cylinder diameter 90 mm  
 Piston stroke 36 mm  
 Total piston displacement 229 cm<sup>3</sup>  
 Mass 11,5 kg  
 Working pressure 800 kPa  
 Max. pressure for short time duty 1000 kPa  
 Max. allowable temp. of compressed air +220 °C  
 Cooling by inflation of air, with the speed of the stream min. - 4 m/s  
 Lubrication forced circulation, splash lubrication  
 min. pressure of oil 300±200 kPa  
 (The pressure drop down is allowed to min. 60 kPa during the idle running of the heated up engine)

**SYMBOLS DESCRIPTION:**

0 - suction connection  
 2 - discharge connection  
 81 - lubricating oil inlet  
 82 - lubricating oil outlet and crankcase breathing  
 T - rating plate  
 Numeral signs according to International Standard ISO-6786

\*\*  
 \*\*\*

**NOTE!** The above characteristics are for open-inlet-valve control system at minimum cooling requirements and at ambient temperature +20°C

**DEFINITIONS:** CC=CT+CL - period of average operating cycle

$UC = \frac{CT}{CC} \times 100\%$  - percent ratio of compressor full load operating time in average operating cycle (also called percent duty cycle)

CL - compressor no-load operating time (exhaust to the atmosphere)

CT - compressor full load operating time

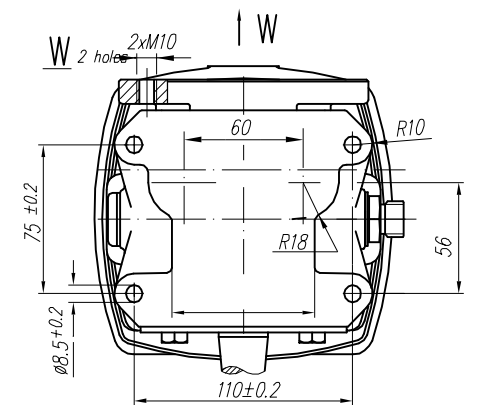
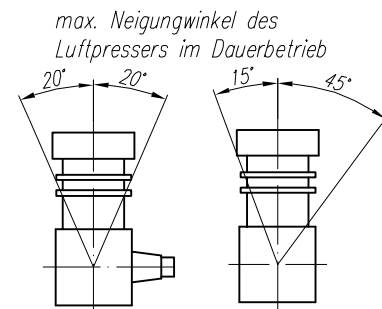
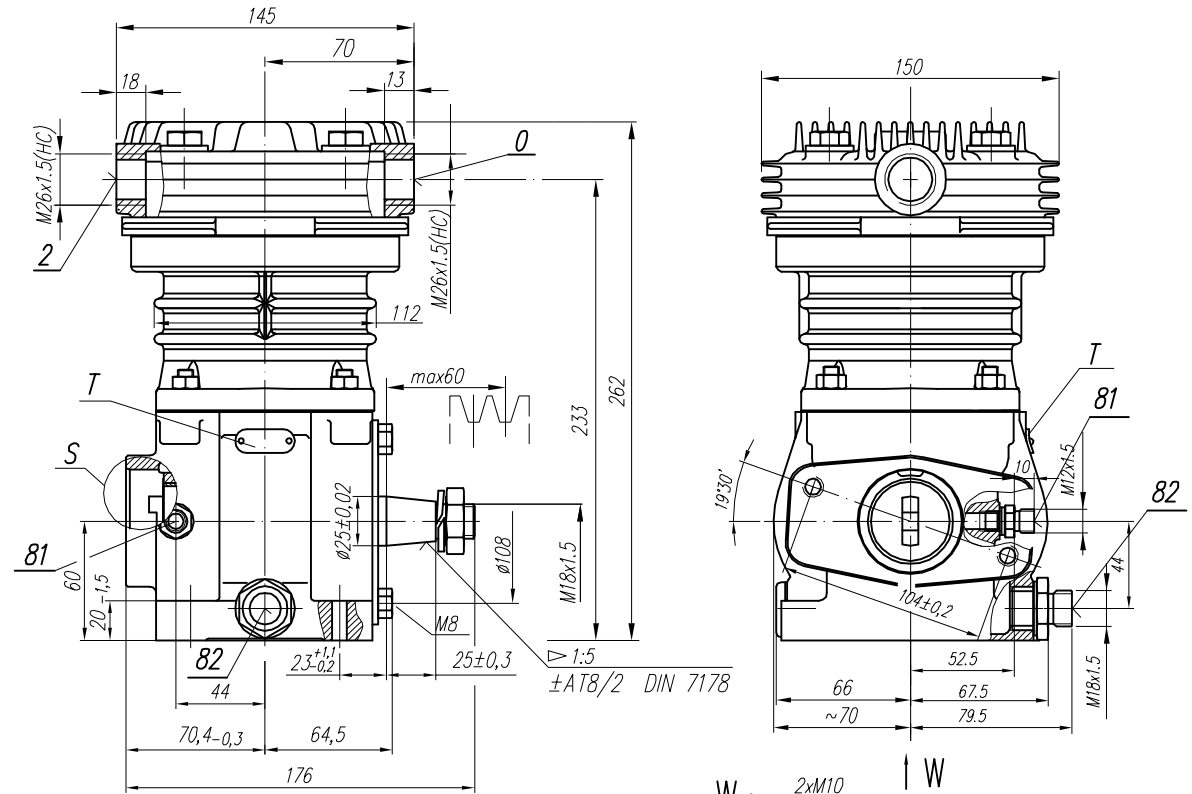
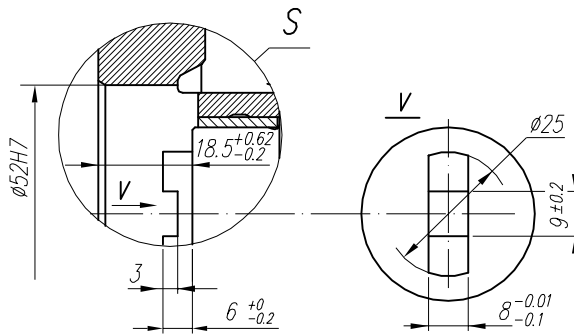

CLASS	GENERAL TOLERANCES				FORCE, POWER PRESSURE ETC.
	RANGE OF NOMINAL DIMENSIONS (±)MM				
II	≤50	>50 ≤180	>180 ≤400	≥400	±3* ±10 %
	1.0	2.0	3.0	4.0	

OFFER DRAWING			
Konstr.	K.Malinowski	06.08.2002	FABRYKA OSPRZĘTU SAMOCHODOWEGO POLMO-KÓDZ S.A. FOS Stuzba Rozwoju
Normaliz.	A.Walnicki		
Sprawdzit	W.Lesiak		
Zatwierdził	W.Lesiak		
Podziałka	Nazwa	1:1 Compressor 601.07.914	